

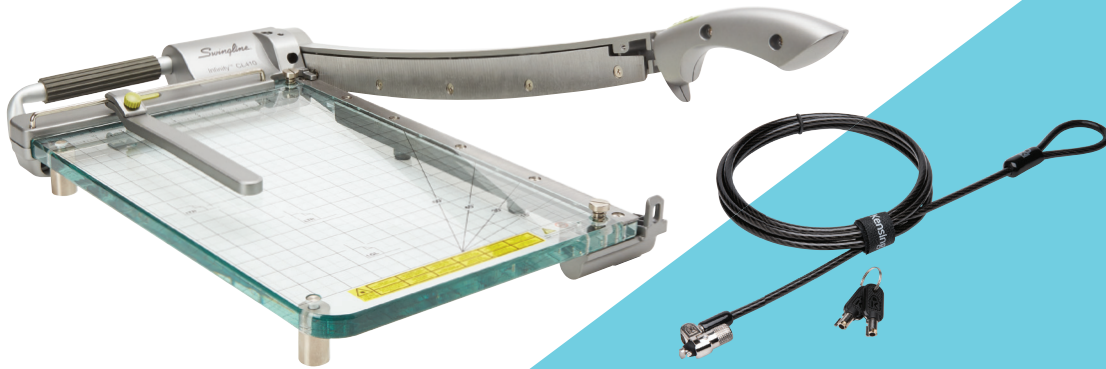

Quartet® *Swingline*



Kensington®



NEW PRODUCTS

2017 CATALOG

ACCO Brands

ACCO Brands has a long history of leadership and innovation in the office products industry. We are focused on delivering exceptional value by providing unique, cutting-edge, branded office products. Our vast offering includes tools that are specifically designed to help you improve productivity, resolve workplace challenges, and stay organized.



As the world's largest provider of whiteboards and bulletin boards, Quartet offers a complete line of innovative products to help employees, students and families stay connected. Our stylish, modular products let customers communicate and collaborate more effectively.



For nearly 90 years, Swingline has been the #1 trusted name in staplers, punches, trimmers and shredders for the home, office and the classroom. The Swingline brand stands for quality, innovation and reliability in office products worldwide.



Swingline, the trusted name in staplers and other fine office products, and GBC, the global leader in binding and laminating, are now joined together to create cutting-edge products that serve the exacting needs of educators, families, and office and print professionals.



For the past 35 years, Kensington has been the global brand professionals choose when they need the most innovative and high-quality security solutions, desktop productivity accessories, and ergonomic products.

Contents

Quartet®	
Boards & Accessories	3-10
Glass Boards, Desktop Easel and Computer Pad, Dry-Erase Markers and Cleaner, Whiteboards	
Swingline®	
Staplers.....	11
Optima® 45 Electric Stapler Value Pack, Commercial Desk Stapler Value Pack, Quick Touch™ Full Strip Metal Staplers	
Swingline®	
Trimmers	12
Infinity™ ClassicCut® Acrylic Guillotine Trimmers	
Swingline® GBC®	
Lamination.....	12
Fusion™ Laminator and EZUse™ Pouches	
Kensington®	
Technology, Accessories & Ergonomics	13-15
Security, Docking Station, Tablet Projection Stand, Monitor Stands, Cooling Stand, Foot Rest, Monitor Arm Mount, Privacy Screens, Portfolios and Sleeves	

Horizon™ Magnetic Glass Dry-Erase Boards



Horizon™ magnetic glass board features a frameless design and concealed tray to match the needs and décor of a contemporary office. The white glass board surface offers classic dry-erase functionality, and the unique accessory tray folds closed for neater storage. Plus, invisible mounting gives the board the appearance of floating on the wall.

Magnetic surface doubles as a bulletin board.

Superior surface. Tempered safety glass will not stain or ghost.

Invisible mount feature gives the dry-erase board a floating appearance.

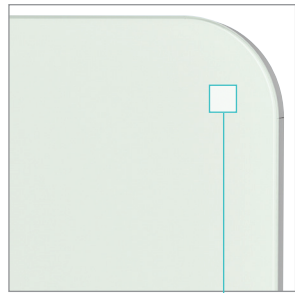

Frameless design features rounded corners and blends into any modern workspace.

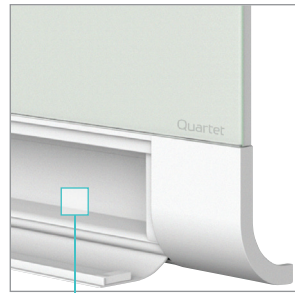

Concealed, full-length accessory tray provides convenient storage.



Quartet® Horizon™ Magnetic Glass Dry-Erase Boards with Concealed Tray

- Glass is magnetic and offers a smooth writing surface. Use with dry-erase markers and rare earth magnets to write messages and post papers.
- Frameless board design has a soft appearance with rounded corners at the top
- Wide format size to match 16:9 aspect ratio projection screens and televisions
- Writing in all colors is easily visible on the white glass board surface. Glass is easy to keep clean with Quartet® whiteboard cleaning supplies.
- Invisible mount with hidden hardware maximizes usable board space and gives the marker board a floating appearance on the wall. Includes template for mounting.
- Concealed tray can keep markers, erasers and more out of sight when board is not in use. Folds open and close to access or conceal items with ease.
- Magnetic glass marker board comes with 1 Quartet® dry-erase marker and 2 round magnets

Frameless			
G3922HT	QRTG3922HT	39" x 22"	\$199.95
G5028HT	QRTG5028HT	50" x 28"	\$399.95
G7442HT	QRTG7442HT	74" x 42"	\$829.95
G8548HT	QRTG8548HT	85" x 48"	\$1,059.95

Evoque™ Magnetic Glass Dry-Erase Boards

Upgrade any office space with this magnetic glass dry-erase board, which features a high-end look with professional appeal. Its modern aesthetics, superior erasability and magnetic surface make it perfect for collaborating in professional environments.



Quartet® Evoque™ Magnetic Glass Dry-Erase Boards with Invisible Mount

- Glass is magnetic and offers a smooth writing surface. Use with dry-erase makers and rare earth magnets to write messages and post papers.
- Black aluminum frame on the sides of the board sits slightly behind board surface for a unique, layered look with professional appeal
- Wide format size to match 16:9 aspect ratio projection screens and televisions
- Writing in all colors is easily visible on the white glass board surface. Glass is easy to keep clean with Quartet® whiteboard cleaning supplies.
- Invisible mount feature with hidden hardware maximizes usable board space and gives the marker board a floating appearance on the wall. Template is provided to aid in mounting accuracy.
- Stylish, clear glass accessory tray is permanently attached below the board surface and is slanted to prevent markers from rolling off
- Magnetic glass marker board comes with 1 Quartet® dry-erase marker and 2 round magnets

Accessories. Durable, clear tempered glass, marker tray provides convenient storage and is angled at a 5° tilt ensuring markers don't roll off.

Black Aluminum Frame			
G3922BA	QRTG3922BA	39" x 22"	\$172.95
G5028BA	QRTG5028BA	50" x 28"	\$349.95
G7442BA	QRTG7442BA	74" x 42"	\$724.95
G8548BA	QRTG8548BA	85" x 48"	\$924.95

InvisaMount™ Magnetic Glass Dry-Erase Boards

Encourage collaboration in the workplace with this magnetic glass dry-erase board. Its frameless, contemporary design fits into any environment seamlessly. Plus, it also lets you align multiple boards to create an extended writing platform.



Quartet® InvisaMount™ Magnetic Glass Dry-Erase Boards

- Glass is magnetic and offers a smooth writing surface. Use with dry-erase makers and rare earth magnets to write messages and post papers.
- Frameless design fits in seamlessly with modern office space décor, and allows boards to be lined up side-by-side for an extended writing platform
- Wide format size to match 16:9 aspect ratio projection screens and televisions
- Writing in all colors is easily visible on the white glass board surface and glass is easy to keep clean with Quartet® whiteboard cleaning supplies
- InvisaMount™ feature with hidden hardware maximizes usable board space and gives the whiteboard a floating appearance on the wall. Template is included to aid in mounting accuracy.
- Included aluminum marker tray is detachable. Clips on easily to store accessories or can be removed for a sleeker look.
- Magnetic glass whiteboard comes with 1 Quartet® dry-erase marker and 2 round magnets

Accessories. Removable accessory tray provides convenient storage.

Frameless board design matches any office décor.

Frameless			
G3922IMW	QRTG3922IMW	39" x 22"	\$151.95
G5028IMW	QRTG5028IMW	50" x 28"	\$309.95
G7442IMW	QRTG7442IMW	74" x 42"	\$643.95
G8548IMW	QRTG8548IMW	85" x 48"	\$819.95

Glass Dry-Erase Desktop Easel and Computer Pad

Keep track of important notes and reminders right on your desktop with this dry-erase desktop easel and computer pad. Both items have stand-up, compact designs to fit perfectly into personal workspaces.



Quartet® Glass Dry-Erase Desktop Easel

- White glass dry-erase desktop easel is infinitely reusable and replaces the need for scrap paper
- Frameless design is sleek and attractive. 9" x 11" board size conserves usable desktop space.
- Position easel upright to keep notes in view while you work. When collapsed the board is not completely flat but angled upward to make writing easier.
- Clipboard-style design allows dry-erase desktop easel to double as a copy holder for letter or A4 size papers
- Back of easel has a built-in storage slot to hold standard size sticky notes
- One Quartet® dry-erase marker with a cap-mounted eraser is included, along with a clip on the back of the board to store the marker

GDE119 QRTGDE119 9" x 11" \$27.95

Quartet® Glass Dry-Erase Desktop Computer Pad

- White glass dry-erase computer pad is infinitely reusable and replaces the need for scrap paper
- Frameless design is sleek and attractive
- 18" x 6" size allows computer pad to fit neatly in between monitor and keyboard, maximizing and making use of all available desktop space
- Glass computer pad is slanted upward for easy reading and writing notes and reminders
- Storage drawer underneath holds sticky notes and other small accessories and can be placed on either side of the board
- Accessory tray across the top holds dry-erase marker
- One Quartet® dry-erase marker with an eraser cap is included

GDP186 QRTGDP186 18" x 6" \$37.95



GDE119



GDP186

Infinity™ Magnetic Glass Dry-Erase Cubicle Boards

Write down great ideas and keep track of daily tasks with this glass surface marker board. Specifically designed for personal use, the board comes with cubicle mount brackets and has a wide format to match modern, low-profile workstations.

Quartet® Infinity™ Magnetic Glass Dry-Erase Cubicle Boards

- Glass is magnetic and offers a smooth writing surface. Use with dry-erase makers and rare earth magnets to write messages and post papers.
- Frameless board design is sleek and attractive
- Board size with a 16:9 aspect ratio fits perfectly in cubicles with low walls and can be hung vertically or horizontally
- Writing in all colors is easily visible on the white glass board surface. Glass is easy to keep clean with Quartet® whiteboard cleaning supplies.
- Two mounting hardware sets included: adjustable brackets to hang board over cubicle walls and wall mount for traditional hanging
- Magnetic glass cubicle board comes with an aluminum accessory tray, 1 Quartet dry-erase marker and 2 rare earth magnets



Frameless			
PDEC2414	Q RTPDEC2414	24" x 14"	\$99.95
PDEC1830	Q RTPDEC1830	18" x 30"	\$129.95

Premium Glass Board Dry-Erase Markers

Dry-erase markers are specifically designed to deliver bold color on glass marker boards. Their liquid ink delivery system and smooth writing tip ensure your messages will stand out on the glass surface.

Quartet® Premium Glass Board Dry-Erase Markers

- Delivers bold color with best in class liquid ink delivery system
- Low odor, easy to erase markers are great for any environment
- Bullet tip creates thick, broad lines for messages that are clear and easy to read both up close and from a distance
- Glass board dry-erase markers feature an ink gauge to clearly see how much ink remains
- Markers are perfect for use with all Quartet® Glass Dry-Erase Boards
- Assorted primary colors include black, blue, red and green

79552	QRT79552	Bullet Tip, Assorted, 4 Pack	\$10.19
79553	QRT79553	Bullet Tip, Black, 12 Pack	\$30.57



Infinity™ Non-Magnetic Glass Dry-Erase Boards

Extremely durable, glass marker boards offer all the benefits of a traditional dry-erase board with an upscale, modern aesthetic appeal. The white glass surface will not stain or ghost. A dry-erase marker glides evenly over the board for smooth and clear communication.

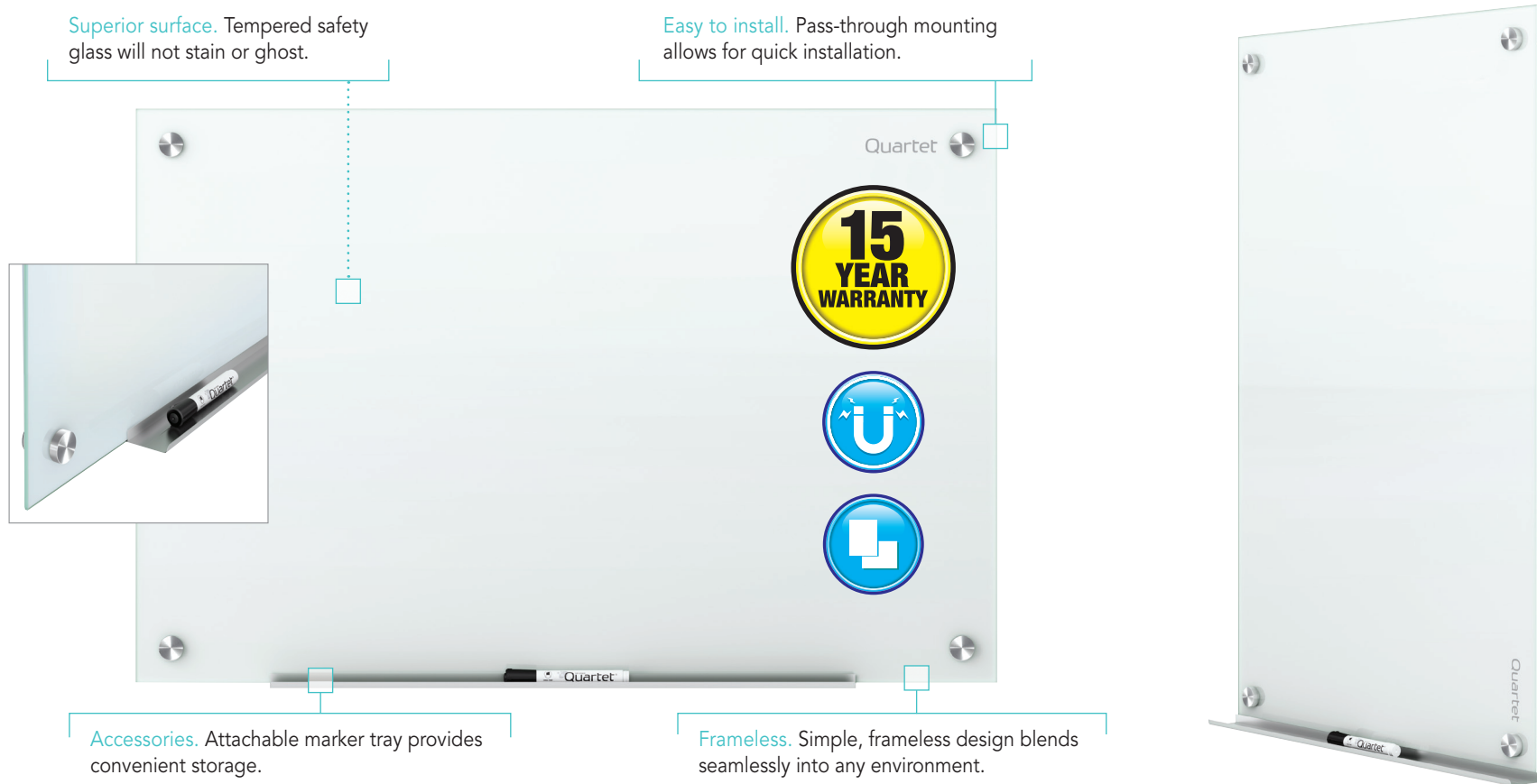

Quartet® Infinity™ Glass Dry-Erase Boards

- Ideal for heavy use in spaces with moderate traffic such as a corporate office
- Frameless board design blends seamlessly into any environment
- White glass board surface is non-magnetic and clearly displays any color dry-erase ink
- Non-absorbent glass board is easy to keep clean with Quartet® whiteboard cleaning supplies
- Board is easy to install with included pass-through mounting hardware. Hang vertically or horizontally.
- Marker tray and one Quartet® dry-erase marker included

Frameless			
G2418NMW	QRTG2418NMW	24" x 18"	\$89.65
G3624NMW	QRTG3624NMW	36" x 24"	\$122.70
G4836NMW	QRTG4836NMW	48" x 36"	\$250.20
G7248NMW	QRTG7248NMW	72" x 48"	\$519.33
G9648NMW	QRTG9648NMW	96" x 48"	\$660.98

Magnetic Glass Dry-Erase Boards

Keep notes and a to-do list in view without taking away from the stylish décor of your space with this glass dry-erase board. Glass surface is durable and smooth, plus the dry-erase board is magnetic to hang photos or printed items.



Quartet® Magnetic Glass Dry-Erase Boards

- Board size is a perfect choice for a personal space in home or office
- Magnetic to hang papers with magnets without damaging glass surface
- Fashionably designed board is frameless and glossy with a thin profile
- Black board surface clearly displays neon color dry-erase ink; red and white surfaces clearly display most colors of dry-erase ink
- Glass is easy to keep clean with Quartet® whiteboard cleaning supplies
- Mounting hardware included for easy installation in your space
- Magnetic glass dry-erase board comes with 1 Quartet® dry-erase marker and 2 rare earth magnets

Frameless			
1212BGB	QRT1212BGB	Black Surface, 12" x 12"	\$32.20
1212WGB	QRT1212WGB	White Surface, 12" x 12"	\$32.20
1212RGB	QRT1212RGB	Red Surface, 12" x 12"	\$32.20
1717BGB	QRT1717BGB	Black Surface, 17" x 17"	\$49.00
1717WGB	QRT1717WGB	White Surface, 17" x 17"	\$49.00
1717RGB	QRT1717RGB	Red Surface, 17" x 17"	\$49.00

Continuum™ Magnetic Whiteboards

This magnetic whiteboard is perfect for communicating in the office. Its frameless design and magnetic mounting let you easily hang multiple boards together, creating a large collaboration space that will help teams bring their ideas to life.

Accessories. Removable magnetic accessory tray provides convenient storage.

Magnetic surface doubles as a bulletin board.

Smart choice. Painted steel surface is stain and ghost resistant.

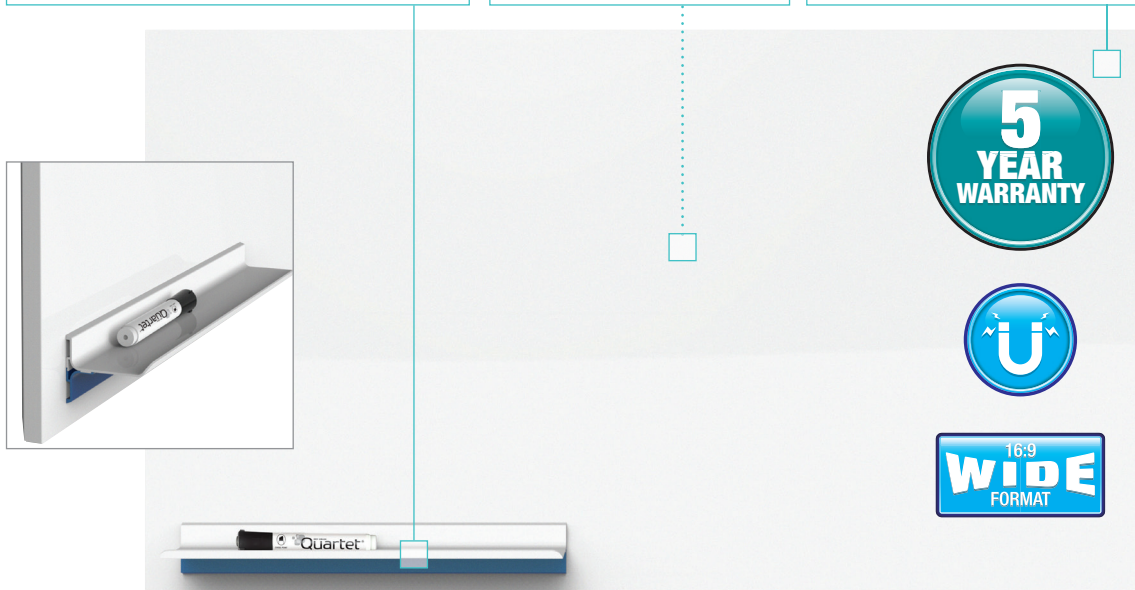

Innovative. Magnetic mounting hardware allows easy and accurate board placement. Each board can be mounted horizontally or vertically.

Quartet® Continuum™ Magnetic Whiteboards

- White surface is magnetic; use with dry-erase markers and standard magnets to write messages and post papers
- Frameless styling is sleek and contemporary, plus provides the ability to mount boards side by side with no interruption
- Wide format design maximizes the usable board space and matches 16:9 aspect ratio projection screens and televisions
- Magnetic mounting system is included for easy and accurate board placement
- Adjustable marker tray is also included, and is magnetic to place anywhere on the board surface to keep accessories close by
- Painted steel board surface is ideal for moderate use and easy to keep clean with Quartet® whiteboard cleaning supplies
- Includes Quartet® dry-erase marker and two magnets

Frameless			
FPS1526	QRTFPS1526	15" x 26"	\$84.95
FPS2239	QRTFPS2239	22" x 39"	\$149.95
FPS2424	QRTFPS2424	24" x 24"	\$109.95
FPS2848	QRTFPS2848	28" x 48"	\$239.95

Whiteboard Cleaner

Wipe any whiteboard free of dry-erase ink and dirt with this plant-based formula cleaner. Just spray and wipe. Perfect for cleaning and maintaining the surface of dry-erase boards that are used daily and require frequent cleaning.



Quartet® Whiteboard Cleaning Spray Refill

- Recognized by the EPA's Safer Choice (DfE) Program; meets U.S. EPA Safer Product Standards
- Removes dry-erase ink, dust and dirt from all whiteboard and dry-erase surfaces
- Regular use helps Quartet® whiteboards resist ghosting and staining
- Suitable for all board types including porcelain, melamine and glass surface marker boards
- Easy to use. For best performance clean board with eraser first, then spray cleaner directly on board surface and wipe with a soft cloth.
- Cleaner is readily biodegradable, non-toxic and low odor (SDS available upon request)
- 1 gallon size cleaner is great for refills – 16 refills of the 8 oz. bottle or 7 1/2 refills of the 17 oz. bottle

920071	QRT920071	Gallon (128 oz)	\$37.99
--------	-----------	-----------------	---------

Staplers

These new staplers are ready to tackle your most demanding jobs. The convenient value packs come with everything you need for seamless daily stapling. And, the new Quick Touch™ staplers offer a boost of power when you need to staple more sheets.



Swingline® Optima® 45 Electric Stapler Value Pack

- Value pack includes the Optima® 45 Electric Stapler, Optima™ Premium Staples and Ultimate Staple Remover
- Electric stapler quietly staples up to 45 sheets at once—2X the capacity of standard electric staplers. Stapler holds a full strip of 210 staples.
- QuickLoad™ feature allows front staple magazine to eject quickly and easily with the press of a button. Plus, low staple indicator alerts you when staples are running out.
- Adjustable depth guide ensures accurate staple positioning while stack height gauge makes sure your papers don't exceed the maximum sheet count
- One-touch easy open storage drawer keeps spare staples handy
- Included staples easily pierce through papers, reducing the risk of jams. Standard 1/4" leg length is ideal for most staple jobs.
- Staples come in strips of 210 to fit perfectly into full size staplers. Includes 5000 staples in a reusable box for neat storage.
- Stapler comes with a 100% performance guarantee and limited 7 year warranty. Staple remover comes with a limited 1 year warranty.

S7048209 SWI48209 Gray Stapler, Metal Staple Remover \$219.07

Swingline® Commercial Desk Stapler Value Pack

- Stapler has a specialized inner rail that reduces risk of jams and can staple up to 20 sheets at a time
- Features durable metal construction that's designed for quality stapling from a desktop. Also includes a positive locking latch that makes sure staples are in proper position for use.
- Stapler opens for tacking to post papers to a bulletin board or other vertical surfaces. Anvil also rotates for a pinning function to create temporary staples.
- Low staple indicator on side of magazine makes it easy to identify when staples run out. Full size stapler holds a full strip of 210 staples.
- S.F.® 4® Staples have a chisel point to easily pierce through papers, reducing the risk of jams. Standard 1/4" leg length is ideal for most staple jobs.
- Staples come in strips of 210 to fit perfectly into full size staplers. Includes 5000 staples in a reusable box for neat storage.
- Retractable blade style Ultimate Staple Remover features a slim, easy to use design for stress-free staple removing
- Built in magnet easily picks up discarded staples
- Stapler includes a limited lifetime warranty. Remover comes with a limited 1 year warranty.

S7044420 SWI44420 Black Stapler, Black Staple Remover \$33.99

Swingline® Quick Touch™ Full Strip Metal Staplers

- Stored energy system ensures stapling 2 sheets or 28 sheets is equally easy
- Jam Free Guaranteed when used with recommended S.F.® 4® Premium Staples
- Staples up to 28 sheets at a time
- QuickLoad™ allows easy staple loading. Staple magazine ejects from the front of the stapler with the push of a button.
- Metal construction delivers lasting durability and provides stylish appeal
- Full size stapler holds a full strip of staples. For optimum performance, use Swingline S.F.® 4® Premium Staples.
- Limited 5 year warranty

S7064584	SWI64584	Blue/Silver	\$39.99
S7064589	SWI64589	Red/Silver	\$39.99

Trimmers

Swingline® sets the standard in stylish office supplies with the new Infinity™ ClassicCut® Acrylic Trimmer. Guillotine style trimmer is crystal clear in color, resembling glass, and has a red laser light to illuminate the cutting line.

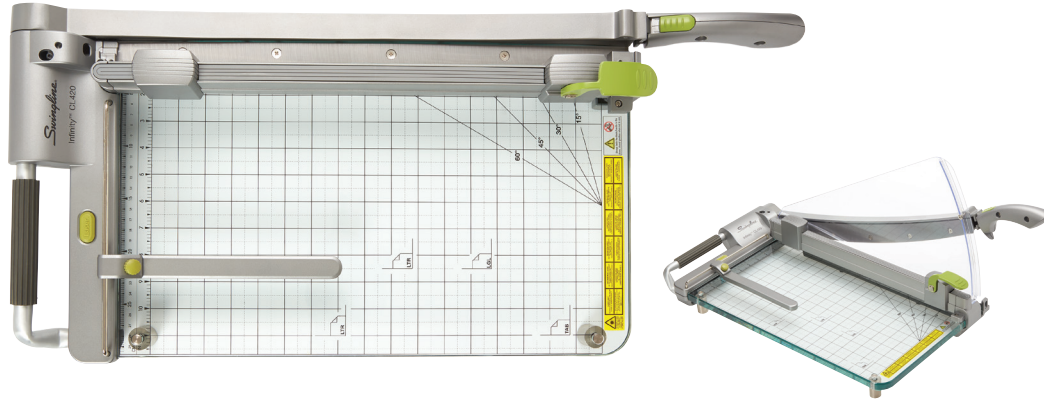

Swingline®

Swingline® Infinity™ ClassicCut® Acrylic Guillotine Trimmers

- Battery powered laser illuminates the cutting line for clear, exact trims
- Inch and centimeter marks and paper size guides are printed on the base to help line up paper
- Adjustable back stop holds documents in place for perfect cutting results
- Convenient document clamp keeps papers in place and reduces fanning while cutting (S7099420 only)
- Cleanly chops through up to 25 sheets at a time to meet the paper trimming needs of the average business
- Guillotine blade is self-sharpening and can lock to prevent accidental blade movement
- Removable, protective cutting shield and carrying handle for safe use and transportation also included
- Limited 10 year warranty

S7099410	SWI99410	Model CL410 - 15.25" Cut	\$350.00
S7099420	SWI99420	Model CL420 - 18.25" Cut	\$412.00

Lamination

Super easy for anyone to use, the Fusion™ 3000L 9" Laminator delivers high quality results. A perfect laminating machine for office use.

Swingline® GBC® Fusion™ 3000L 9" Laminator

- Warms up in only 1 minute. Laminating speed of 19" per minute.
- Intelligent Jam Alert System™ beeps until button is pressed to release jammed pouch
- Maximum document width of 9"
- Use with 3 and 5 mil thermal pouches
- Cold setting available for smooth lamination results with pressure sensitive pouches
- Green ready light and audible ready alert indicate when warm-up is complete
- Intelligent Auto Power Off™ after 30 minutes of inactivity conserves energy
- Includes 30 EZUse™ pouches
- Limited 3-year warranty



1703079	SWI1703079	9" Laminator, Black	\$169.00
---------	------------	---------------------	----------

Swingline® GBC® EZUse™ Pouches

- Thermal lamination pouch includes visible EZUse™ features that magically disappear after lamination
- Alignment guides make centering documents easy
- Mil icons clearly identify pouch thickness to help you select best laminator settings
- Directional arrows indicate which edge of pouch should be loaded into laminator first
- UV protection prevents fading and discoloration over time
- Letter Speed Format available with seal on the long edge for the fastest lamination
- Multiple sizes, mil thicknesses and pack quantities available

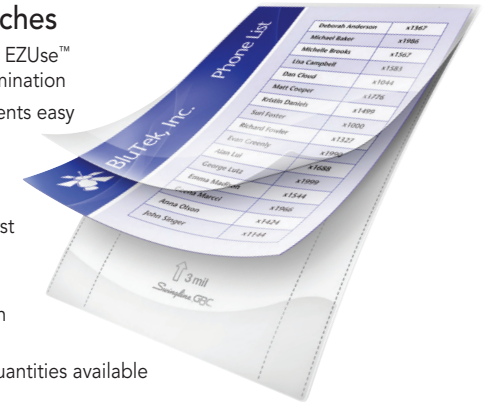

3740721	SWI3740721	Standard Letter Size, 3 mil, 150 Pack	\$67.99
3740722	SWI3740722	Speed Letter Size, 3 mil, 150 Pack	\$67.99
3740723	SWI3740723	Standard Letter Size, 5 mil, 150 Pack	\$89.99
3740724	SWI3740724	Speed Letter Size, 5 mil, 150 Pack	\$89.99
3740725	SWI3740725	Standard Letter Size, 3 mil, 200 Pack	\$73.99
3740726	SWI3740726	Speed Letter Size, 3 mil, 200 Pack	\$73.99
3740727	SWI3740727	Standard Letter Size, 5 mil, 200 Pack	\$95.99
3740728	SWI3740728	Speed Letter Size, 5 mil, 200 Pack	\$95.99

Technology Accessories



Kensington is a leading provider of desktop and mobile device accessories, trusted by IT, educators, business and home office professionals around the world. In both office and mobile environments, our extensive portfolio of award-winning products provides trusted security, desktop productivity innovations, and ergonomic well-being.



Kensington® MicroSaver® 2.0 Keyed Laptop Lock

- Strong 10mm lock head offers uncompromised security for even the thinnest laptops and devices
- Patented Hidden Pin™ Technology supports anti-pick tubular lock
- T-Bar™ Locking Technology attaches to the Kensington Security Slot™ found on most laptops
- Carbon steel cable resists cutting attempts and anchors to desk, table or any fixed structure
- Pivot and Rotate cable provides superior laptop engagement
- Independently Verified & Tested for industry-leading standards in torque/pull, foreign implements, lock lifecycle, corrosion, key strength and other environmental conditions
- Register & Retrieve™ program allows you to order replacement keys



K65020 KMW65020 Keyed Lock \$57.45

Kensington® SD3600 Universal USB 3.0 Mountable Docking Station

- Dual 1080p HD video to external monitor via HDMI, VGA or DVI
- Mounting plate allows the dock to be placed on the back of a VESA-compatible monitor
- 2 front USB 3.0 ports that support high-speed data transfer up to 5Gbps
- 4 rear USB 2.0 ports for peripheral accessories like a keyboard and mouse
- Display settings software allow you to easily make changes to your preferences
- Headphone and microphone jacks with Audio 2.0 for enhanced sound quality
- Gigabit Ethernet port for wired connectivity to a network or the Internet



K38234 KMW38234 Black \$195.45





1) MEASURE: Place hand on SmartFit chart to determine your color setting



2) ADJUST: Set up the product according to your color setting



3) FIT: Experience the ergonomic comfort of your personalized fit

Kensington® Tablet Projection Stand

- Sturdy, adjustable aluminum stand is stable yet lightweight, height adjustable, offers 180° pitch tilt and 360° rotation, and tightly secures tablet
- Easily converts your tablet into a presentation tool so you can show on a larger screen any object you want using the tablet's camera
- Connect and project by connecting a video cable to a projector, monitor or TV
- Universal fit accommodates 7"-11" tablets with or without cases
- Cable management system keeps cords organized and creates a less cluttered working environment



K97447 KMW97447 Accommodates 7"-11" Tablets \$149.45

Kensington® SmartFit® Spin2™ Monitor Stand

- SmartFit® System lets you adjust monitor height to your personal comfort color
- Patented 360-degree spinning carousel organizes common desktop accessories
- Stand positions monitor in line with your eyes to help reduce eye and neck strain
- Small footprint helps conserve valuable desktop space
- Platform fits most widescreen monitors up to 40 lbs.



K52787 KMW52787 Black \$67.10

Kensington® SmartFit® Easy Riser™ Laptop Cooling Stand

- SmartFit® System lets you adjust height of the screen and angle of the laptop to your personal comfort color
- Increases air circulation to keep your laptop cooler, easing strain on the components and battery
- Padded inserts provide a secure, stable fit and keep your laptop in place
- Up to 50 degree tilt angle
- Folds flat to travel easily
- Fits notebooks 12" to 17"



K52788 KMW52788 Black \$34.95

Kensington® SmartFit® Monitor Stand Plus

- SmartFit® System lets you adjust monitor height to your personal comfort color, by snapping risers into place
- 3 height settings (3" to 6")
- Stand positions monitor in line with your eyes to help reduce eye and neck strain
- Extra-wide universal platform design fits any monitor up to 24" and 80 lbs.
- 11.5" clearance between the legs under the stand provides plenty of storage for accessories or papers to optimize desktop space



K52786 KMW52786 Black \$60.18

Kensington® SmartFit® Monitor Stand

- SmartFit® System lets you adjust monitor height to your personal comfort color, by snapping risers into place
- 3 height settings (1 7/8" to 5 7/8")
- Stand positions monitor in line with your eyes to help reduce eye and neck strain
- Universal platform design fits any monitor up to 21" and 40 lbs.
- 8 1/4" clearance between the legs under the stand provides plenty of storage for accessories or papers to optimize desktop space



K52785 KMW52785 Black \$46.24

Kensington® SmartFit® Solemate™ Plus Foot Rest

- SmartFit® System lets you adjust foot rest to your personal comfort color using foot pedal
- Promotes a stress-reducing seating position to support your feet, legs and lower back
- Height adjusts from 3.5"-5" and angle adjusts up to 30 degrees
- Foot pedal allows you to make adjustments while remaining seated
- Large, non-skid surface provides great stability



K52789 KMW52789 Black \$77.17

Kensington® SmartFit® Dual Monitor Arm Mount

- SmartFit® System allows you to find your personal comfort color within 4 height regions for optimal ergonomics
- Monitors attach via 75mm or 100mm VESA-compatible mounts
- Cable management system helps neatly route cords for a clutter-free desktop
- Assembles to the edge of the desktop via grommet clamp in just minutes
- Compatible with displays up to 24"; maximum 25 lbs. per arm

K60273 KMW60273 Hold up to 24" monitors \$229.95



Kensington® Privacy Screens

- Limits viewing angle to +/- 30°, hiding personal or confidential information from anyone trying to look from the side
- Reduces harmful blue light by up to 30%
- Can be installed using the included frameless tab holders or double-sided tape
- Anti-reflective coating reduces glare and improves clarity
- Anti-microbial additive decreases film degradation
- Reversible with matte and glossy viewing options
- Protects the monitor screen from scratches and damage
- Cleaning cloth included

K52791	KMW52791	FP116W9 Privacy Screen for 11.6" Chromebook™	16:9 aspect ratio	\$40.45
K52792	KMW52792	FP125W9 Privacy Screen for 12.5" Laptops	16:9 aspect ratio	\$40.45
K52793	KMW52793	FP140W9 Privacy Screen for 14" Laptops	16:9 aspect ratio	\$45.95
K52795	KMW52795	FP240W9 Privacy Screen for 24" Widescreen Monitors	16:9 aspect ratio	\$114.95
K52794	KMW52794	FP240W Privacy Screen for 24" Widescreen Monitors	16:10 aspect ratio	\$114.95

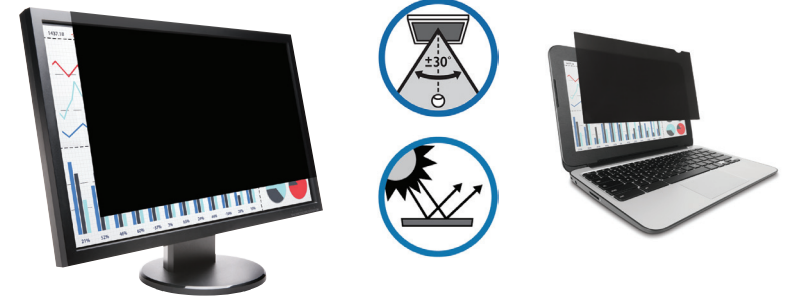

Kensington® LS510 Portfolio for 11.6" Chromebook™

- Protective solution that features EVA foam bumpers, a faux leather cover, soft inner lining and magnetic flap
- Ventilation channels ensure proper air flow to prevent overheating
- Strategic cutouts provide access to power jack and USB ports
- Hand strap provides convenient and safer option to carry the portfolio
- Stay-on straps for screen corners lift open the Chromebook, offer stability
- ID window quickly helps identify each student's device
- Fits into Kensington Charging Cabinets
- Inner rubber feet help prevent wear and tear

K64417 KMW64417 Black \$40.45



Kensington® LS430 Sleeve for Chromebook™ and MacBook Pro

- Compatible with 13.3" Chromebooks™ and 13" MacBook Pro
- Reinforced protection panel helps keep screen from getting cracked or damaged
- "Stay on" straps securely hold corners of the Chromebook
- Plush-lined interior protects device from getting scratched
- Padded handles provide a comfortable and stable carry solution
- Pull tab lets you easily lift the sleeve out of a backpack

K62844 KMW62844 Black \$28.95





ACCO Brands
Four Corporate Drive
Lake Zurich, IL 60047-8997
In USA call 800.541.0094
www.accobrand.com

Kensington®, Swingline® and ACCO® names and designs are registered trademarks of ACCO Brands. GBC® and Quartet® names and designs are registered trademarks of General Binding Corporation. Fusion™ is a trademark of ACCO Brands. All other brands or product names are trademarks or registered trademarks of their respective holders. Minimum order quantities may apply. Colors are subject to change.

©2017 ACCO Brands. All Rights Reserved.

13127E001