



# Wide Format Application Guidebook

This guidebook is divided into two color-coded categories, based on the type of ink used in your wide format printer, and includes recommendations on which GBC film/media to use when making the following types of applications:

Aqueous Inkjet Applications	Solvent Inkjet Applications
<ul style="list-style-type: none"> <li>Trade show graphics</li> <li>Display rollups</li> <li>Floor graphics</li> <li>Wall murals</li> <li>Backlit signage</li> <li>Indoor/outdoor banners</li> <li>Window graphics</li> <li>Mounted indoor/outdoor signage</li> <li>Anti-graffiti signage</li> <li>Magnetic signage</li> </ul>	<ul style="list-style-type: none"> <li>Outdoor vinyl banners</li> <li>Floor graphics</li> <li>Anti-graffiti signage</li> <li>Rigid signage</li> <li>Vehicle graphics</li> <li>Window graphics</li> <li>Backlit signage</li> </ul>

The following symbols will be used throughout the guide:

## Processes

Thermal Process	Pressure Sensitive Process	Thermal/Pressure Sensitive Process

## Ratings

Three Gold Star – Best Solution	Two Silver Star – Good Solution	One Bronze Star – Suitable Solution

The wide format applications in this guide use GBC recommended products. While compatibility of the recommended products has been tested, it is vital that applications be tested in their actual environments. Many factors can impact the longevity and compatibility of products. It is important to understand these factors and adjust the applications as necessary.



# Wide Format Application Guidebook

## Trade Show Graphics

	Application	Media	Laminates
	Backwall	SurePrint® Ultra Dry Blockout Polyester	Octiva® Lo-Melt Textured Satin 10mil
			Octiva® Lo-Melt Gloss 10mil
	Backwall	SurePrint® White Polyester	Octiva® Lo-Melt Textured Satin 10mil
			Octiva® Lo-Melt Light Barrier 11mil
	Backwall	SurePrint® Ultra Dry Matte or similar paper media	Octiva® Lo-Melt Textured Satin 10mil
			Octiva® Lo-Melt Light Barrier 11mil

- The Ultra Dry receptive coating on the SurePrint® media allows thermal films to adhere to the polyester.
- When using the SurePrint® White Polyester, allow a minimum of 2 hours cure time after lamination before trimming the image.
- Adjust laminate film thicknesses based on desired flexibility and rollability. For example, Octiva® Lo-Melt Textured Satin 5mil can be substituted to increase flexibility.
- Paper media offers a low cost solution for short-term trade show graphics.

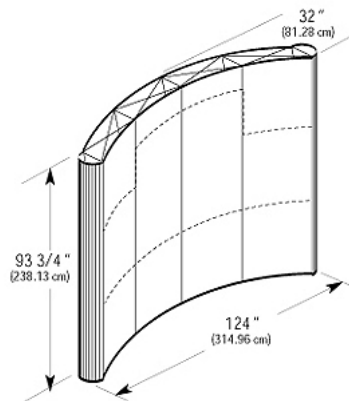



# Wide Format Application Guidebook

## Display Roll-ups

	Application	Media	Laminates
	Roll-up	SurePrint® Ultra Dry Blockout Polyester	Octiva® Lo-Melt Emboss 50
			Kraft paper
	Roll-up	SurePrint® Ultra Dry Matte	Octiva® Lo-Melt Textured Satin 3mil
			Octiva® Lo-Melt Light Barrier 3mil

- Using Octiva® Lo-Melt Emboss 50 allows the graphic to stay flat. Do not use an additional laminate on the back of the graphic.
- Total thickness should be less than 14mil to ensure the graphic can roll up properly.
- When using the SurePrint® Ultra Dry Blockout Polyester 7mil and Octiva® Lo-Melt Emboss 50, be sure to use heat only on the top roller.

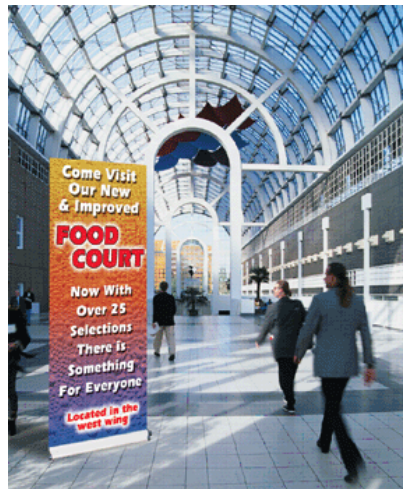



# Wide Format Application Guidebook

## Floor Graphics

	Application	Media	Laminates
	Permanent floor graphic	SurePrint® Adhesive-back Vinyl	Arctic® Floor Mat
			Kraft paper
	Removable floor graphic	SurePrint® Ultra Dry Matte or SurePrint® White Polyester	Arctic® Floor Mat
			Arctic® Removable

- Arctic® FloorMat is a UL listed material that meets the recommended standards for slip resistance.
- Be sure to leave a sealed edge around the graphic when using paper or polyester media.
- If the graphic requires contour cuts or routing, it is recommended to use the permanent floor graphic solution.





# Wide Format Application Guidebook

## Wall Murals

	Application	Media	Laminates
	Mounted via magnet or Velcro	SurePrint® Ultra Dry Matte	Octiva® Lo-Melt Textured Satin 5mil
			Octiva® Lo-Melt Gloss 10mil
	Adhered to the wall – permanent	SurePrint® Ultra Dry Matte	Arctic® Textured Satin 3mil
			Arctic® Premium Mount
	Adhered to the wall - removable	SurePrint® Ultra Dry Matte	Arctic® Textured Satin 3mil
			Arctic® Removable
	Adhered to the wall – permanent	SurePrint® Adhesive-back Vinyl	Arctic® UV Cast Sand
			Kraft paper

- Any SurePrint® paper or polyester media can be used with the Best Solutions.
  - Use SurePrint® Photobase Gloss or Satin for higher density of color.
  - Use SurePrint® White Polyester for increased durability.
- Laminates of any finish can be used for these solutions. For example, Octiva® Lo-Melt Matte Hardcoat 5mil could be used instead of Octiva® Lo-Melt Textured Satin 5mil. Customer preference will dictate.
- Shipping costs can be significantly decreased by sending materials that can be rolled and then mounted on location.



# Wide Format Application Guidebook

## Backlit Signage

	Application	Media	Laminates
	Inserted backlit	SurePrint® Translucent Polyester	Arctic® UV Cast Sand <hr/> Kraft paper
	Mounted backlit – second surface	SurePrint® Translucent Polyester	Otiva® Cold Mount OC <hr/> Otiva® Lo-Melt Gloss
	Mounted backlit – second surface	SurePrint® Translucent Polyester	Arctic® Vue-Thru <hr/> Kraft paper

- Any finish may be used with an inserted backlit. Consider the graphic’s environment when deciding.
  - Outdoor – Arctic® UV Cast Sand/Gloss, Arctic® Select, or Arctic® Graffiti
  - Indoor – Arctic® Gloss/Lustre/Matte, Arctic® Polycarbonate, Arctic® Textured Satin
- Otiva® Cold Mount OC is a combination thermal and pressure sensitive material. It is applied to the image with heat and then cold mounted to the substrate.





# Wide Format Application Guidebook

## Indoor/Outdoor Banners

	Application	Media	Laminates
	Indoor vinyl banner	SurePrint® Outdoor Scrim Vinyl	AccuShield® <hr/> Kraft paper
	Indoor vinyl banner	SurePrint® Outdoor Scrim Vinyl	Arctic® Gloss <hr/> Kraft paper
	Indoor banner	SurePrint® Ultra Dry Matte	Octiva® Lo-Melt Gloss 5mil <hr/> Octiva® Lo-Melt Gloss 5mil
	Outdoor vinyl banner	SurePrint® Outdoor Scrim Vinyl	Arctic® UV Cast Gloss <hr/> Kraft paper

- Different finishes are available for indoor/outdoor laminating films. Consider the environment when deciding on the proper laminate to use.







# Wide Format Application Guidebook

## Window Graphics

	Application	Media	Laminates
	Indoor – mounted	SurePrint® Ultra Dry Matte	Arctic® Lo-Tack
			Kraft paper
	Indoor – mounted	SurePrint® White Polyester	Arctic® Lo-Tack
			Kraft paper
	Indoor – first surface mounted – removable	SurePrint® Ultra Dry Matte	Arctic® Lustre
			Arctic® Removable
	Outdoor mounted – permanent	SurePrint® Adhesive-back Vinyl	Arctic® UV Cast Gloss
			Kraft paper

- Different finishes are available for indoor/outdoor window graphics. Consider the application when deciding.
- Arctic® Lo-Tack is a clear removable adhesive applied most commonly to the face of the graphic. The channeled adhesive system allows the graphic to be hand mounted, easily repositioned (temporarily), and removed without leaving a residue for up to 3 months after installation.







# Wide Format Application Guidebook

## Mounted Indoor/Outdoor Signage

	Application	Media	Laminates
	Mounted to paper substrate – indoor	SurePrint® Photobase Satin	Octiva® Scuff Free Matte
			Octiva® Cold Mount White
	Mounted to paper substrate – indoor	SurePrint® Photobase Satin	Arctic® Lustre
			Arctic® Dura Mount
	Mounted to plastic substrate – indoor	SurePrint® Photobase Satin	Arctic® Lustre
			Arctic® Premium Mount
	Mounted to plastic substrate – indoor	SurePrint® Photobase Satin	Octiva® Scuff Free Matte
			Octiva® Cold Mount White
	Mounted to plastic substrate – outdoor	SurePrint® Adhesive-back Vinyl	Arctic® UV Cast Gloss
			Kraft paper

- Different adhesives are available depending on the substrate:
  - Arctic® Dura Mount – excellent all-around economical adhesive for multipurpose use
  - Arctic® White Mount – white adhesive for added opacity when mounting to colored substrates
  - Arctic® Image Barrier – blocks out previously mounted images so the substrate can be reused
  - Arctic® Premium Mount – high initial tack for the most demanding applications



# Wide Format Application Guidebook

## Anti-Graffiti Signage

	Application	Media	Laminates
	Mounted	SurePrint® Adhesive-back Vinyl	Arctic® Graffiti
			Kraft paper
	Banners	SurePrint® Outdoor Scrim Vinyl	Arctic® Graffiti
			Kraft paper
			Kraft paper

- Arctic® Graffiti uses a substrate that resists the effects of harsh solvents allowing the graphic to be cleaned should it be vandalized.



# Wide Format Application Guidebook

## Magnetic Signage

	Application	Media	Laminates
	Mounted	SurePrint® Adhesive-back Vinyl	Arctic® UV Cast Gloss
			Magnetic Stock
	Mounted	SurePrint® Ultra Dry Photobase Matte	Arctic® UV Cast Gloss
			Arctic® Dura Mount
			Magnetic Stock

- Arctic® White Mount or Arctic® Premium Mount can be substituted for Arctic® Dura Mount
- Using a paper media offers a cost effective solution, but the potential for splitting is increased over the use of an adhesive-backed vinyl